

# Revolving Tailstock Centres

The present compilation provides information about applications, special features together with the most important data. The load values given in the individual tables are based on speed at 100RPM

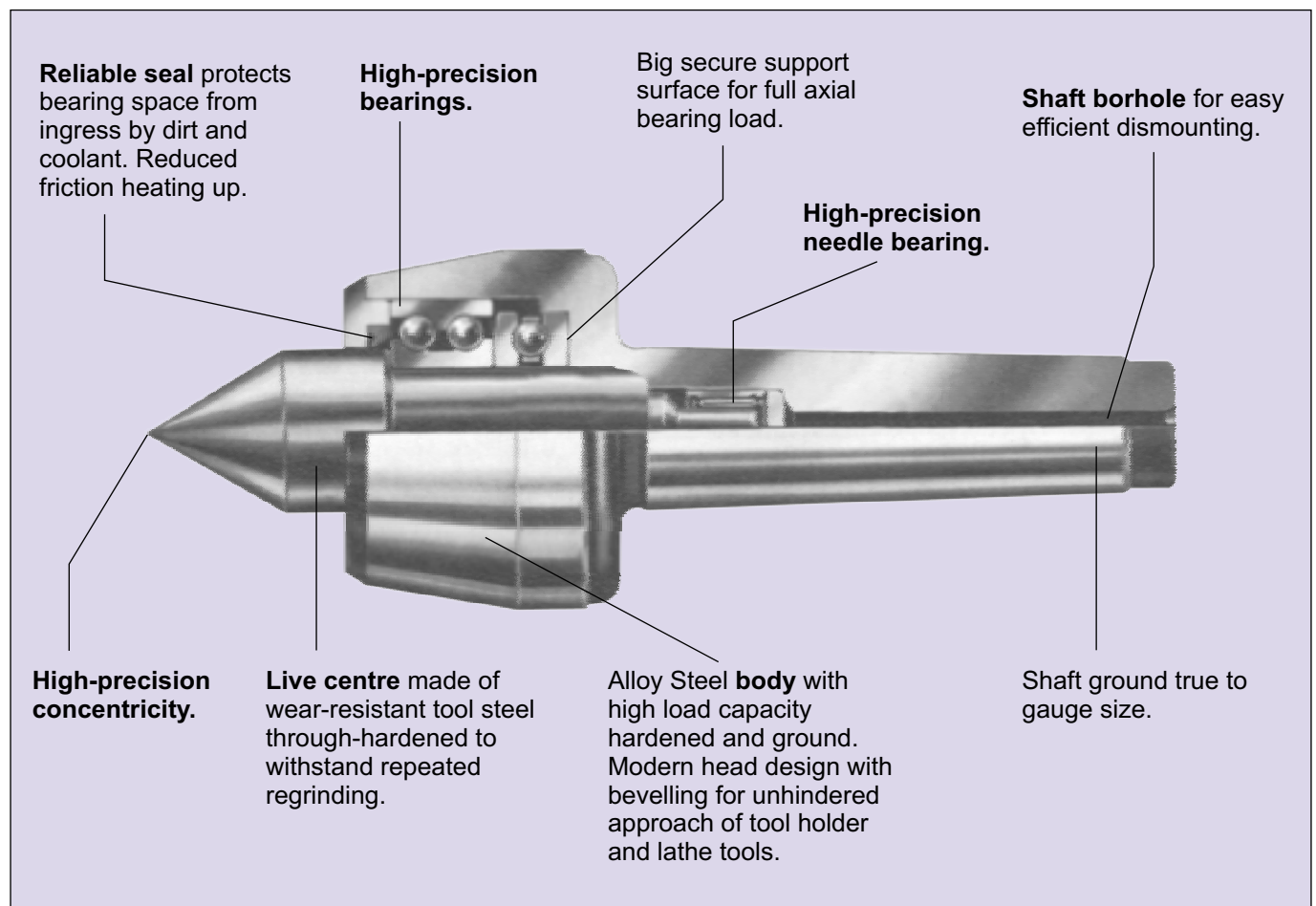

## INDUSTRIAL TOOLS CORPORATION

■ 54/14, D-II, M.I.D.C., Chinchwad, Pune - 411 019. • Tel.: 020-7474394, 7470844

■ 302, Vicky Apartment, P. Balu Marg, Mumbai - 400 025. • Tel.: 022 2430 5959 Telefax : 022 2436 1221

Visit us at : [www.indl-tools.com](http://www.indl-tools.com) • E-mail : [indltool@vsnl.com](mailto:indltool@vsnl.com)

# Revolving Tailstock Centres

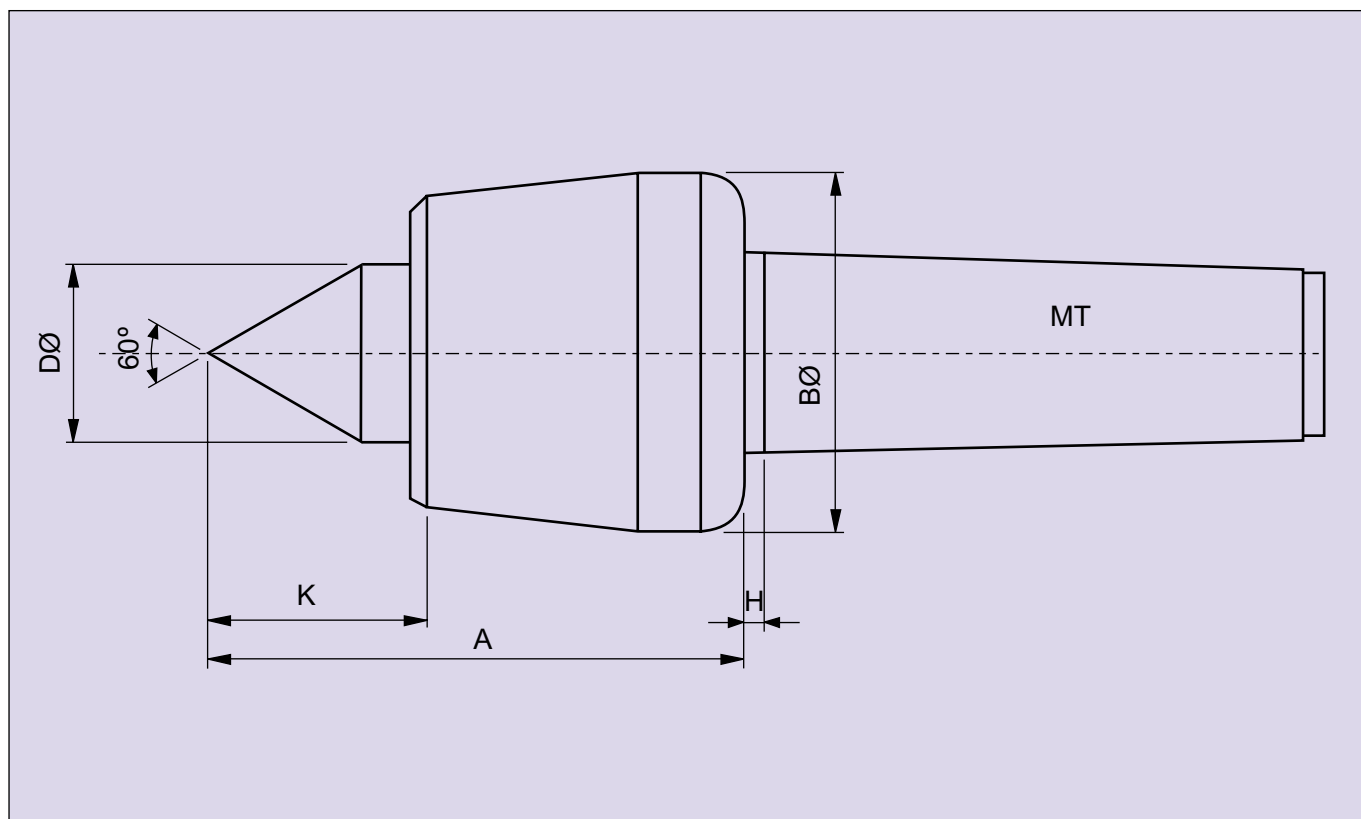

Tip angle 60 : **Type 640 H** - Body hardened and ground

Dia gage plain	MT	Indent no.	Workpiece weight max Kg	Concentr. error max.	Speed RPM	A apprx.	K apprx.	B Dia apprx.	D Dia	H	Weight apprx Kg.
12.065	1	640H101	75	0.005	5000	54	17	36	15	6	0.5
17.78	2	640H102	150	0.005	5000	58	24	45	20	7	0.6
23.825	3	640H103	350	0.005	4000	64	27.5	50	25	6.5	1.3
31.267	4	640H104	650	0.005	3100	92	41	70	32	8.5	2.3
44.399	5	640H105	1400	0.005	2100	120	50.5	90	40	8.5	4.7
63.348	6	640H106	3500	0.005	1500	139	57.5	105	50	13	10.7

Specification subject to change without notice due to continuous improvement.



## INDUSTRIAL TOOLS CORPORATION

■ 54/14, D-II, M.I.D.C., Chinchwad, Pune - 411 019. • Tel.: 020-7474394, 7470844

■ 302, Vicky Apartment, P. Balu Marg, Mumbai - 400 025. • Tel.: 022 2430 5959 Telefax : 022 2436 1221

Visit us at : [www.indl-tools.com](http://www.indl-tools.com) • E-mail : [indltool@vsnl.com](mailto:indltool@vsnl.com)